

V Series Chassis Mount Sunlight Readable TFT LCD

Model: VCHH3200

The VCHH3200 is a Color Active Matrix Liquid Crystal Display with an integral External Electrode Fluorescent Lamp (EEFL) backlight system. The matrix employs a-Si Thin Film Transistor as the active element. It is a V Series type(1) display operating in the normally Black mode. This TFT-LCD has 32.0 inches diagonally measured active display area with WXGA resolution (768 vertical by 1366 horizontal pixel array). Each pixel is divided into Red, Green and Blue sub-pixels or dots which are arranged in vertical stripes. Gray scale or the brightness of the sub-pixel color is determined with a 8-bit gray scale signal for each dot, thus, presenting a palette of up to 16.7 millions color. The VCHH3200 has been designed to apply the interface method that enables low power. Flat Link must be used as a LVDS (Low Voltage Differential Signaling) chip. The VCHH3200 is intended to support applications where thin thickness, low power are critical factors and graphic display are important. In combination with the vertical arrangement of the sub-pixels, the VCHH3200 characteristics provide an excellent flat display for office automation products such as Public information, public transportation and outdoor application where sunlight readability is critical.

V Series type means that has a function of transmissive and reflective mode in a body and it is able to use at indoor or outdoor under dark and sunlight at all.

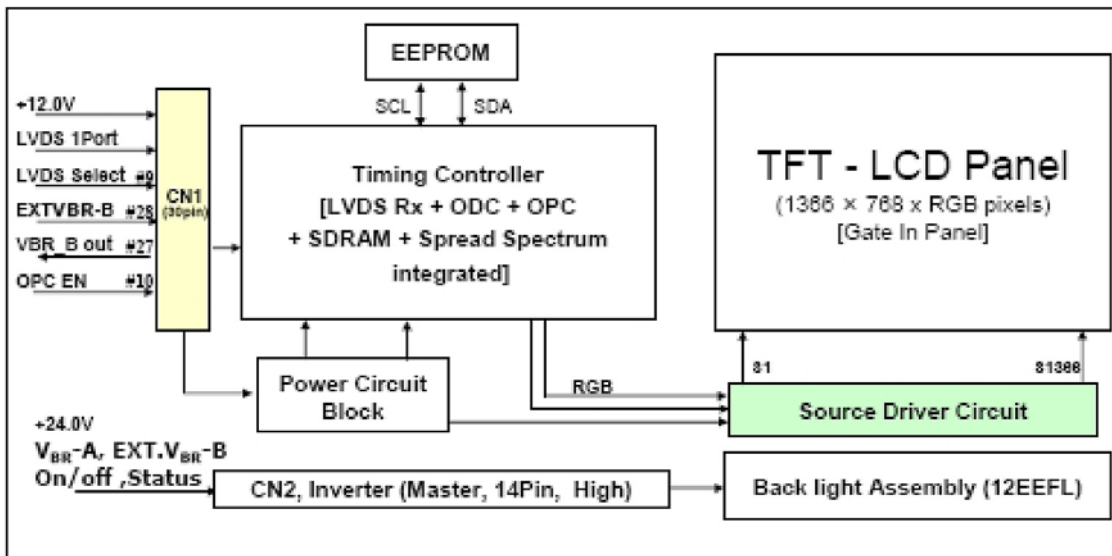

Features:

Active screen size	32 inches(80.04cm) diagonal
Outline Dimension	760.0(H) x 450.0(V) x 48.0(D) mm (Typ.)
Pixel format	1366 horiz. By 768 vert. Pixels (RGB stripes arrangement)
Color depth	8-bit , 16.7M colors
Luminance (white)	900 cd/m2 (Typ.) at center 1 point
Reflectance	2.5 % (Max.)
Power consumption	87.8 Watt at B/L ON (3.8 Watt at B/L OFF)
Weight	6770 g (Max.)
Display operating mode	Sunlight Readable mode, Normally Black
Surface treatments	UV coating (Max.2%) and Low reflection treatment of the front polarizer

Optical Specifications

Parameter		Values			units	Note	
		Min.	Typ.	Max.			
At Indoor	Brightness	750	900	-	cd/m2		
	Contrast Ratio	-	1550	-	-		
	Viewing angle (CR ≥ 10)	Left	-	88	-	degree	
		Right	-	88	-	degree	
		Top	-	88	-	degree	
Bottom		-	88	-	degree		
Color coordinates	White X-axis	Typ	0.295	Typ.	-		
	White Y-axis	-0.05	0.320	+0.05	-		
At 80Klux	Reflectance	-	-	2.5	%		
	Brightness	-	1500	-	cd/m2		
	Contrast Ratio	-	150	-	-		
Response time	Rise time + Fall time	-	9	14	msec		

Conditions: (Ta=25±2 °C, VLCD=12.0V, fV=60Hz, Dclk=72.4MHz, VBR-A=VBR-B=3.3V)

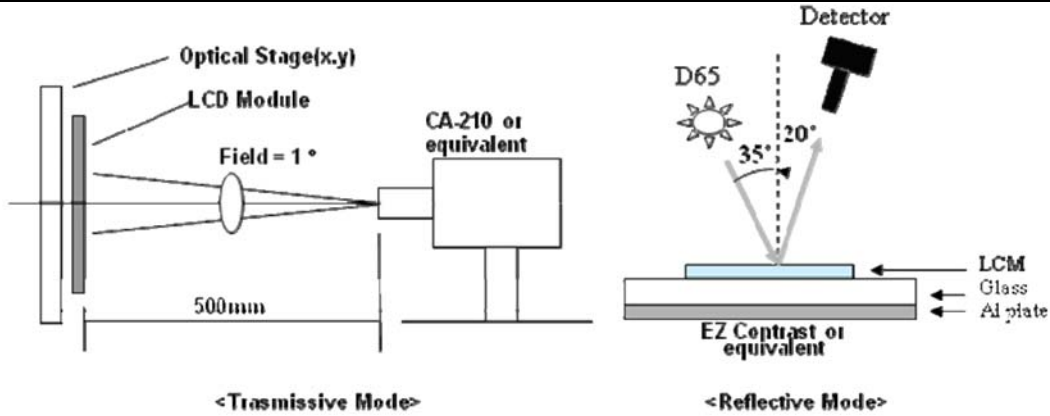

(Optical Characteristic Measurement Equipment and Method)

Mechanical Drawing

