

V Series Chassis Mount Sunlight Readable TFT LCD

Model: VCHH1900

The VCHH1900 is a Color Active Matrix Liquid Crystal Display with an integral Cold cathode Fluorescent Lamp (CCFL) backlight system. The matrix employs a-Si Thin Film Transistor as the active element. It is a V Series type(1) display operating in the Normally white mode. This TFT-LCD has 19.0 inches diagonally measured active display area with SXGA resolution (1024 vertical by 1280 horizontal pixel array). Each pixel is divided into Red, Green and Blue sub-pixels or dots which are arranged in vertical stripes. Gray scale or the brightness of the sub-pixel color is determined with a 8-bit gray scale signal for each dot, thus, presenting a palette of up to 16.7 M colors. The VCHH1900 has been designed to apply the interface method that enables low power. Flat Link must be used as a LVDS (Low Voltage Differential Signaling) chip. The VCHH1900 is intended to support applications where thin thickness, low power are critical factors and graphic display are important. In combination with the vertical arrangement of the sub-pixels, the VCHH1900 characteristics provide an excellent flat display for office automation products such as Public information, public transportation and outdoor application where sunlight readability is critical.

V Series type means that has a function of transmissive and reflective mode in a body and it is able to use at indoor or outdoor under dark and sunlight at all.

FIG. 1 Block diagram

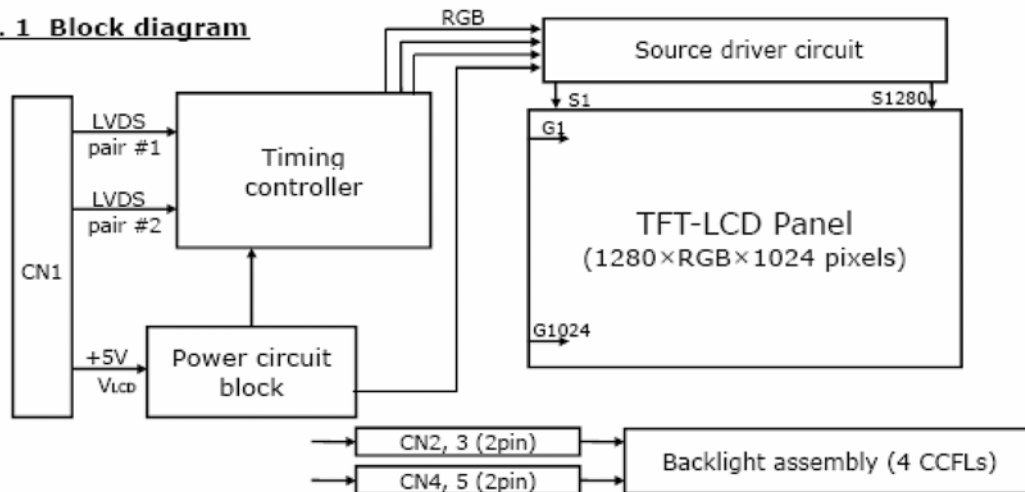

Features:

Active screen size	19.0 inches (48.19cm) diagonal
Outline Dimension	396.0(H) x 324.0(V) x 15.5 (D) mm (Typ.)
Pixel format	1280 horiz. By 1024 vert. Pixels (RGB stripes arrangement)
Color depth	LVDS 2port, 8-bit , 16.7M colors
Luminance (white)	420 cd/m2 (Typ.) at center 1 point
Reflectance	2.5 % (Max.)
Power consumption	25.1 Watt at B/L ON, (4.5 Watt at B/L OFF)
Weight	2050 g (Max.)
Display operating mode	Sunlight Readable mode, Normally White
Surface treatments	UV coating(Max.2%) and Low reflection treatment of the frontpolarizer

Optical Specifications

Parameter		Values			units	Note	
		Min.	Typ.	Max.			
At Indoor	Brightness	350	420	-	cd/m2		
	Contrast Ratio	-	760	-	-		
	Viewing angle (CR ≥ 10)	Left	-	88	-	degree	
		Right	-	88	-	degree	
		Top	-	88	-	degree	
Bottom		-	88	-	degree		
Color coordinates	White X-axis	Typ	0.310	Typ.	-		
	White Y-axis	-0.05	0.328	+0.05	-		
At 80Klux	Reflectance	-	-	2.5	%		
	Brightness	-	850	-	cd/m2		
	Contrast Ratio	-	370	-	-		
Response time	Rise time + Fall time	-	5	10	msec		

(Ta=25±2 °C, VDD=5.0V, fV=60Hz, fDclk=54MHz, IL=7.5mArms)

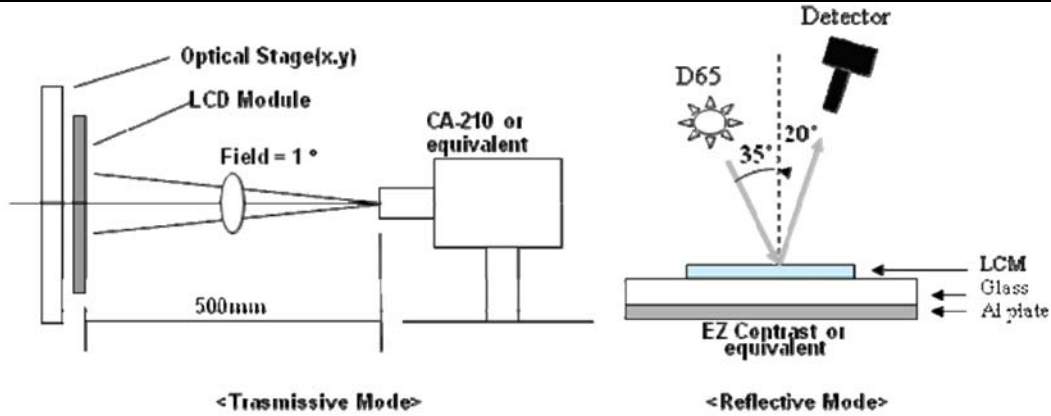

(Optical Characteristic Measurement Equipment and Method)

Mechanical Drawing

